

SUMMARY

- Rapid Prototyping Platform for D.Module2 DSP, FPGA and FMC Mezzanine Boards
- Vita 57 FMC LPC Mezzanine Site
- D.Module2.DSP and D.Module2.FPGA Site
- 12V Single Power Supply
- PCIe, USB, Ethernet and RS232 Interfaces
- Patch Area with additional DSP and FPGA signals
- Size: Eurocard 160x100mm

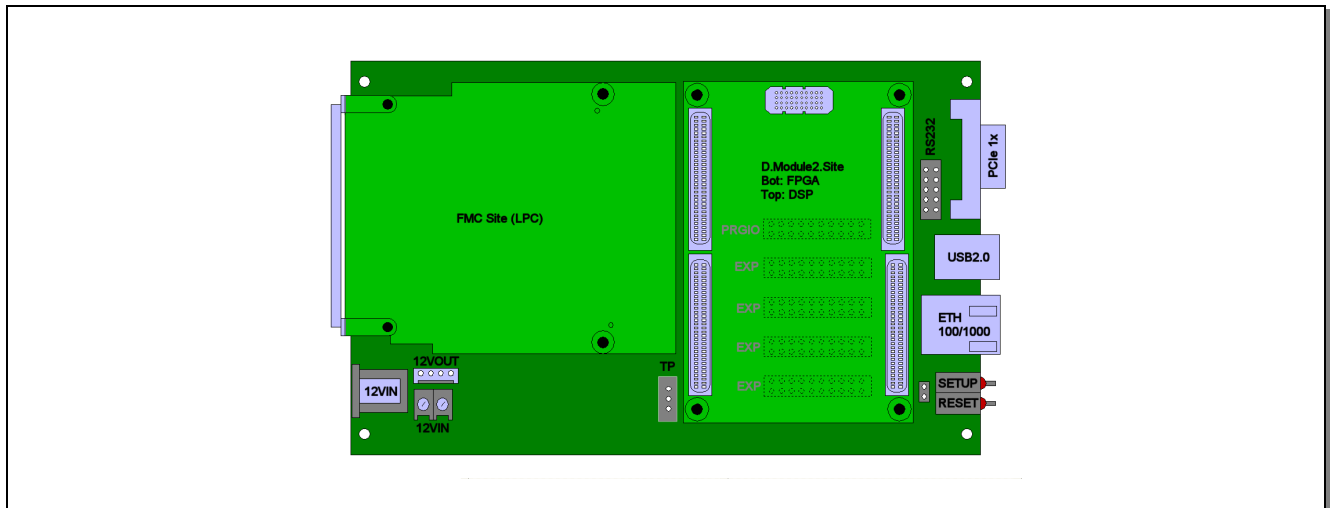

The D2.Base-FMC is a prototyping and evaluation platform for the D.Module2 family of DSP and FPGA boards. An Ansi Vita 57 compliant FMC LPC IO site allows to use industry-standard mezzanine boards: A/D and D/A data acquisition, Video and Camera interfaces, Digital Radio frontends etc.

The FMC site LPC connector is routed to the D.Module2 site. The D.Module2.FPGA provides data (pre-)processing. A D.Module2.DSP board can be mounted on top of the FPGA board for further processing.

The D.Module2 site features various communication interfaces which are accessible on the front panel: 1-lane PCIe, High-Speed USB2.0, and Ethernet (100Base-Tx or 1000-Base-T). Also provided is an RS232 port and additional FPGA and DSP I/O signals, which are accessible on a patch area below the D.Module2 site.

The power supply is a single 12V input. All other voltages are generated on board. The FMC mezzanine VADJ voltage supply is programmable by either DSP or FPGA via I²C bus.

D.MODULE2 SITE

Suitable for D.Module2 FPGA and DSP boards.

Interfaces:

- USB2.0 High Speed (480 Mb/s) Type-B connector
- Ethernet (100Base-Tx or 1000-Base-T) RJ45 connector
- PCIe 1x cable connector
- RS232 10pin (2x5) IDC header
- PRGIO and EXP connector signals accessible on patch area
- two pushbuttons (Reset and Setup)
- two LEDs (Power 12V and 3.3V)
- two programmable testpoints (GPIO[3:2])

FMC MEZZANINE SITE

Conforming to Vita 57 FMC LPC

- 68 single-ended / 34 LVDS IO signals to/from D.Module2 site LA[33:00]

- two LVDS clocks to D.Module2 site
- Supported I/O standards: LVDS, LVCMOS18, LVCMOS25, LVCMOS33, LVTTTL (not supported are IO standards requiring a reference voltage like SSTL, HSTL)
- Supported VADJ voltages: 1.8, 2.5, and 3.3V
- one Gigabit Interface with reference clock connected to D.Module2 site
- I²C interface to D.Module2 site
- JTAG signals are available on a patch area

POWER SUPPLY

12V single supply input

- barrel-type plug or screw-type terminals
- on board switching regulators: 3.3V 6A (opt. 10A) programmable VADJ regulator (1.8, 2.5, 3.3V) 1.8A

BLOCK DIAGRAM

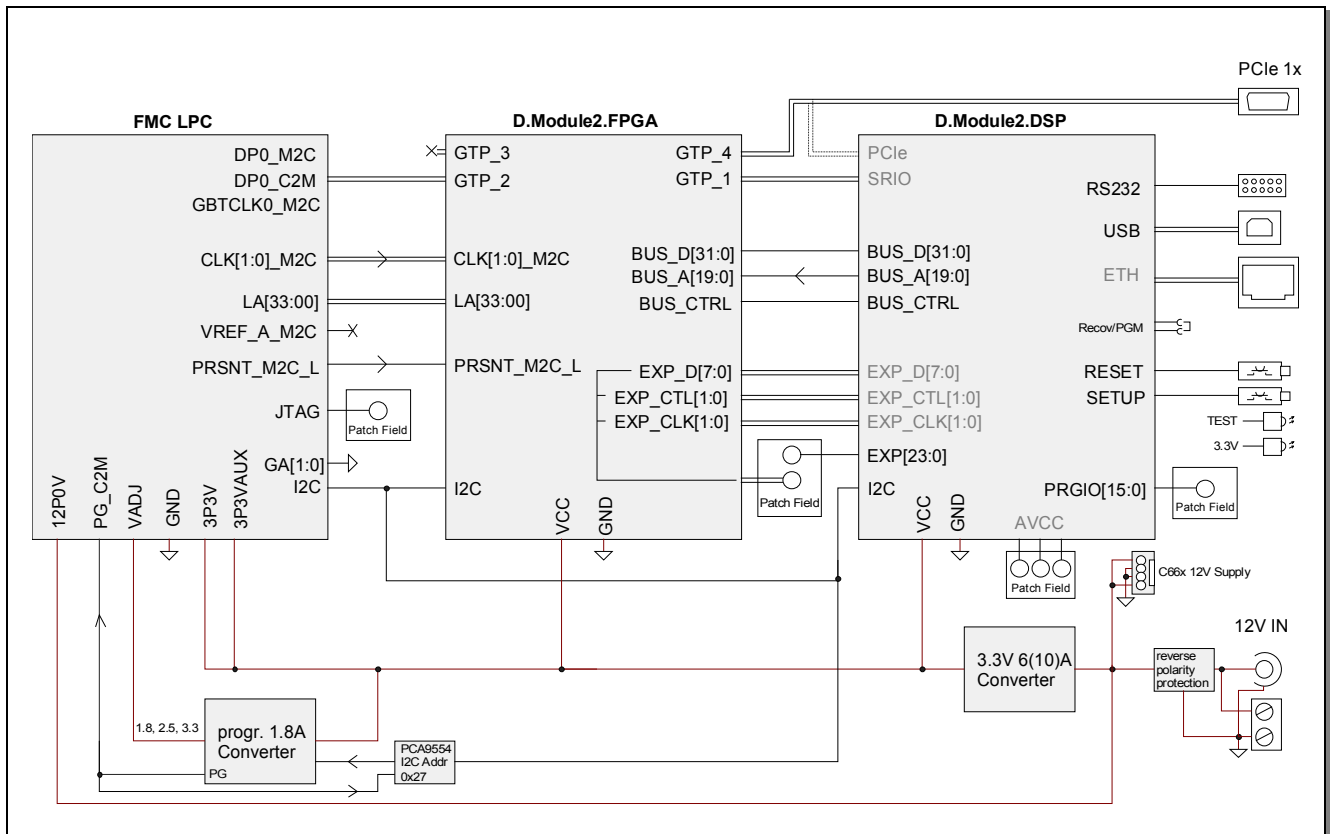

SYSTEM INTERCONNECTS

The FMC site is connected to the D.Module2.FPGA via

- a Gigabit Link DP0 (one lane) with a reference clock provided by the FMC mezzanine card.
- 68 single-ended or 34 LVDS signals LA[33:00] with up to four dedicated clock signals
- two LVDS clocks provided by the FMC mezzanine card CLK[1:0]_M2C
- an I²C interface

Either DSP or FPGA board can be used as I²C master to read the FMC configuration EEPROM and configure the VADJ power supply.

The D.Module2 FPGA and DSP by default communicate via a 32-bit wide data bus with 20 address lines and an I²C interface. If supported by the DSP, the following communication paths can be used alternatively:

- a Serial Rapid IO link, one lane
 - 8 LVDS data lines, control lines and clocks on the Expansion Bus (e.g. TigerSharc Link Ports) .
- If not used for DSP-FPGA communication, these signals are available as additional DSP or FPGA I/O on a patch area below the D.Module2 site.

A PCIe interface (one lane) is connected to the D.Module2 FPGA board. Optionally this interface can be re-routed to the DSP board if the DSP features PCIe

CONNECTORS

External PCIe x1	Molex 74960-3018 mating connector: Molex 74155-0001 or equivalent mating cable: Molex 74576-000x (x=0,1,2,...) or equivalent mating Cable Adapter Cards (examples): <ul style="list-style-type: none">- Innovative Integration 80181-0 (Desktop PC)- One Stop Systems OSS-PCIe-HIB2-x1 (Desktop PC)- One Stop Systems OSS-PCIe-HIB2-EC-x1 (Laptop Express Card) Sideband Signals: <ul style="list-style-type: none">- CPERST# connected to FPGA GPIO0- CPRSNT# connected to FPGA GPIO1- CWAKE# and CPWRON are not connected- Sideband Signals are not isolated, SB_RTN = GND
USB 2.0	Type B connector, 12MBit/s and 480MBit/s
Ethernet	RJ-45 (8P8C modular connector) 10BASE-T, 100BASE-TX, 1000BASE-T
RS232	2x5 header, 2.54mm pitch for IDC10 cable Pnout (DSP view): <ul style="list-style-type: none">1 - DCD DSR - 2 DCD - DSR - DTR interconnected3 - TXD CTS - 45 - RXD RTS - 67 - DTR NC - 89 - GND NC - 10
Power Supply	12V 2.5mm barrel-type plug (center-tip positive) or screw -type terminals

ORDER INFORMATION

D2.Base-FMC	standard board incl. power supply
Options	-

Additional Options On Volume Purchase

For volume purchase D.SignT offers customer specific modifications of the hardware either to reduce costs through reduced functionality or to increase functionality to meet the customers application requirements. Extensive experience in custom designs and the powerful engineering tools of our development department bring your application and our DSP know how together for your solution. Please contact D.SignT directly.

Technical Support

Our products include free of charge technical support. You can reach the technical support by e-mail (support@dsigt.de) phone or fax.

Pricing

Please ask for our current price list and volume discounts.

Availability

Our standard D.Modules are available typically ex-stock.- For special modifications or non-standard D.Module2 please consult our sales department.

Warranty

All D.Module2 boards come with a 12 month warranty .

For additional information contact your local distributor or D.SignT directly.

Distributed and supported locally by

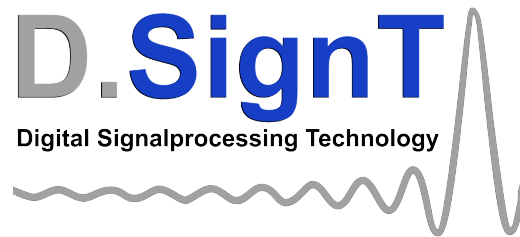

D.SignT GmbH & Co. KG
Marktstr. 10
D-47647 Kerken

phone +49 (0) 2833 / 570 977
fax +49 (0) 2833 / 33 28
email info@dsigt.de
www <http://www.dsigt.de>