

FEATURES

- 10 / 100 MBit/s Ethernet Media Access Controller
- 100 Base-Tx / 10 Base-T Physical Interface
- Real-Time-Clock
- MultiMediaCard Slot
- TCP/IP Protocol Stack available
- 5V tolerant Bus Interface 16 or 32 bit wide
- supports Busy-Polling, DMA and Interrupt Mode
- 3.3V Single Supply
- Glueless Interface to D.Module DSP Boards
- Small Size: 85 x 59 mm

APPLICATIONS

- High Speed Data Transfer Link
- Remote Access Configuration and Maintenance
- Distributed Control Systems
- Video Surveillance
- Multimedia and Telecommunications

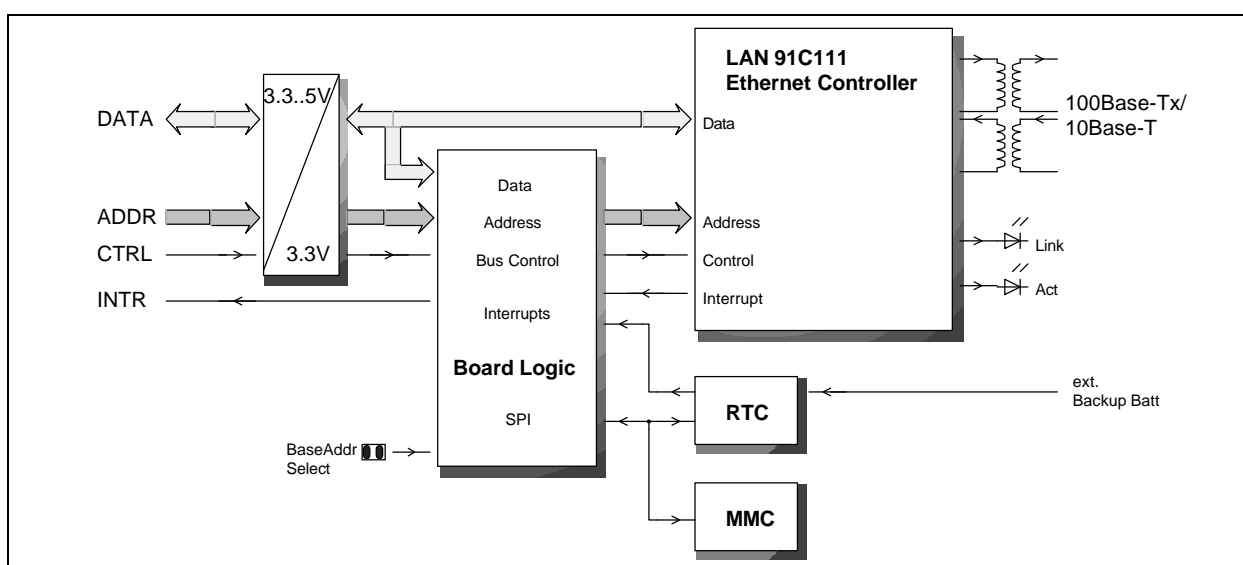

The D.Module.91C111 is a Networking Peripheral Daughter Module for the D.Module family of DSP based Computer Modules. It extends your DSP system with an industry standard 100 Base-Tx / 10 Base-T Ethernet interface for distributed control applications, network and web-based remote configuration and maintenance, and/or a high speed data link for Video, Multimedia and Telecommunication Systems.

The Ethernet Controller is accompanied by other peripheral devices, typically required for network-

based applications: a real-time clock to provide time stamps for file transfers, and a MultiMediaCard slot for non-volatile mass storage.

A TCP/IP software protocol stack is available, which has been carefully optimized for the special memory and real-time constraints of DSP systems. No underlying real-time operating system is required to integrate the TCP/IP protocol into your DSP system.

Ethernet Controller

The D.Module.91C111 is based on the SMSC 91C111 Ethernet Controller. It offers 8 Kbytes internal fifo memory for frame buffering. The network interface supports auto-negotiation, full- and half-duplex mode.

Real-Time Clock

Network protocols often require to keep track of timeouts for re-transmission and acknowledge of data transfers. These timeouts may be in an order of several seconds or even minutes if used in a wide

area network (WAN). File transfers and data logging requires exact time stamps. The D.Module.91C111 therefore integrates an RTC, which is accessed via an SPI serial interface. The RTC may be battery-buffered, short-term power losses up to a few minutes are buffered by a large on-board capacitor. The RTC provides status information about power losses. It also features software calibration which allows to adjust deviations of the clock in units of 3ppm.

MultiMediaCard Slot

Remote configuration and Maintenance is typically based on file transfers between the DSP system and one or more remote hosts. Often a HTTP server is integrated, which allows to access and configure the system from anywhere via an Internet connection. HTML pages, graphics, images and scripts can be stored conveniently on a MultiMediaCard, which offers non-volatile storage capacity ranging from 8 to 256 Mbytes. File transfers, e.g. via FTP, can use the MultiMedia Card too. Since the DSP board's internal Flash Memory is not directly accessed, file transfers are safe, there is no risk to damage the DSP's boot code. The DSP may also write system log files to the MMC, which can be downloaded, viewed and analyzed via the network. The MultiMediaCard, like the RTC, is accessed via the D.Module.91C111 built-in SPI interface.

MEMORY MAP

The D.Module.91C111 is decoded via the nIOSEL input (active low), and address lines A18, A17, A16 and A5, A4 Jumpers for A18..A16 select one of eight 64K banks, and A5, A4 select one of four 16 words address spaces within each bank. The following tables shows the possible base addresses of the D.91C111

Offset from nIOSEL Base Addr.		JPA18	JPA17	JPA16
C6000 DSP	other DSPs			
0x00.0000 (factory setting)	0x04.0000	closed	open	open
0x04.0000	0x05.0000	closed	open	closed
0x08.0000	0x06.0000	closed	closed	open
0x0C.0000	0x07.0000	closed	closed	closed
*	0x00.0000	open	open	open
*	0x01.0000	open	open	closed
*	0x02.0000	open	closed	open
*	0x03.0000	open	closed	closed

* not possible on C6000 DSP Modules, the C6000 DSPs always drive A18 high in IOSEL memory area

Offset in 64 K Block		JPA5	JPA4
C6000 DSP	other DSPs		
0x00 (factory setting)	0x00	open	open
0x40	0x10	open	closed
0x80	0x20	closed	open
0xC0	0x30	closed	closed

Bus Interface

The variety of DSP architectures calls for a flexible bus interface. The D.Module.91C111 is a memory mapped peripheral, connected to the DSP system's external bus. To accommodate to different bus speeds, the interface can be configured to request wait states from the DSP if required. The minimum bus access time of 60 nsecs guarantees high throughput. The D.Module.91C111 supports 16 and 32 bit wide data bus architectures. 16 words address space are occupied by the D.91C111.

The MultiMediaCard and Real-Time Clock are accessed via SPI interface. The SPI interface is an 8-bit memory-mapped device, which can be used in busy-polling and interrupt driven mode. A clock prescaler register controls the SPI clock speed, depending on the DSP module bus clock.

Two interrupt lines can be individually enabled and mapped to the Ethernet Controller, the RTC alarm function, and/or the SPI interface.

Power Supply

The D.Module.91C111 operates from a single 3.3V power supply. Power consumption is 160mA (530 mW) typically.

REGISTER MAPPING

Address Offset		Register			
C6000 Modules	Other	Bank 0	Bank 1	Bank 2	Bank 3
0x00	0x00	TCR	Config	MMU	MCast1
0x02	0x01	EPH_Stat	Base	PN	MCas2
0x04	0x02	RCR	Addr0	FIFO	MCast3
0x06	0x03	Counter	Addr1	Ptr	MCast4
0x08	0x04	MIR	Addr2	DataL	MII
0x0A	0x05	RPC	GP	DataH	REV
0x0C	0x06	RES	CTL	IS	ERCV
0x0E	0x07	Bank Select Register			
0x10..0x1F	---	Alias of 0x00..0x0F			
0x20	0x08	32 Bit Ethernet Data Register			
0x24	0x09	-			
0x28	0x0A	-			
0x2C	0x0B	-			
0x30	0x0C	Configuration Register(CONFIG)			
0x34	0x0D	SPI Clock Prescaler (SPIPRE)			
0x38	0x0E	SPI Control Register (SPICTRL)			
0x3C	0x0F	SPI Data Register (SPIDATA)			

SIGNAL DESCRIPTION

External Bus Interface

Signal	Pin	Type	Description
D0 .. D15 D16..D31	V15 .. V30 U15..U30	I/O/Z	data bus
A0 .. A5 A16..A18	U9 .. U14 V12..V14	I	address bus
nBE0..nBE3	T8..T11	I	Byte Enables, used with C6000 DSP modules only
nIOSEL	U8	I	select signal, active low, decodes module combined with address bus
nRD	U2	I	read strobe, active low
nWR	U5	I	write strobe, active low
BUSCLK	U6	I	bus clock input
nRESET	U7	I	module reset input, active low
nWAIT	A10	O/Z	wait state request, active low, 3state if module is not accessed
nINT0	U3	O/Z	interrupt request, active low, 3state if INTO_EN bit is '0'
nINT1	U4	O/Z	interrupt request, active low, 3state if INT1_EN bit is '0'

100 Base-Tx / 10 Base-T Interface

Signal	Pin	Type	Description
RD-	1	I	Ethernet Receiver, typically connected to RJ45 pin 6
RD+	2	I	Ethernet Receiver, typically connected to RJ45 pin 3
TD-	4	O	Ethernet Transmitter, typically connected to RJ45 pin 2
TD+	5	O	Ethernet Transmitter, typically connected to RJ45 pin 1

Misc. Signals

Signal	Pin	Type	Description
VBATT+	8	PWR	Backup Battery for RTC
VBATT-	9	PWR	Backup Battery for RTC
LINKLED	10	O	external Link LED
ACTLED	11	O	external Network Activity LED

MECHANICAL DIMENSIONS

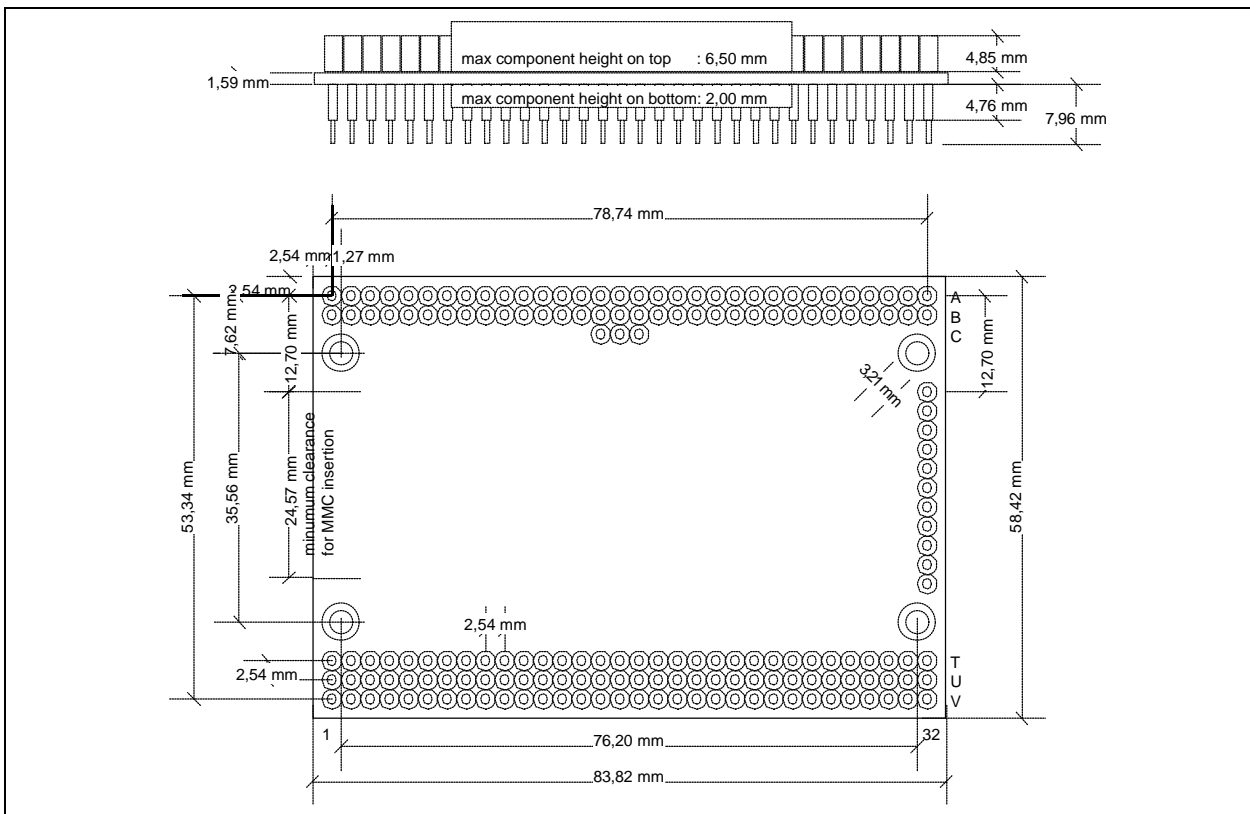

Weight: max. 20g

ELECTRICAL CHARACTERISTICS

DC Parameters and recommended operating conditions

Supply Voltage VCC	3.3V +/- 5%
Power Consumption	typ.: 160 mA (loopback test)
Operating Temperature	0 .. +70°C
High Level Input Voltage	min. 2V, max. 5.5V
Low Level Input Voltage	min. -0.2V, max. 0.8V

AC Parameters

Bus Clock	max. 160 MHz
Access Time	60 ns (the Ethernet Controller may request additional wait states if required)

ORDERING INFORMATION

D.Module.91C111	Ethernet Network Daughter Module
D.Module.91C111-SL	D.Module.91C111 plus TCP/IP protocol software (single system license for small volumes)
D.Module.91C111-OL	TCP/IP protocol OEM software license for higher volumes
DS.91C111	Board Support Package, including support software in C source code, test board, and TCP/IP protocol software library

ADDITIONAL OPTIONS ON VOLUME PURCHASE

For volume purchase D.SignT offers customer-specific modifications of the hardware either to reduce costs through reduced functionality or to increase functionality to meet the customers application requirements. Extensive experience in custom designs and the powerful engineering tools of our development department bring your application and our DSP know how together for your solution. Please contact D.SignT directly.

TECHNICAL SUPPORT

Our products include free of charge technical support. You can reach the technical support by e-mail (support@dsigt.de) phone or fax.

PRICING

Please ask for our current price list and volume discounts.

AVAILABILITY

Our standard D.Modules are available typically ex-stock. For special modifications or non-standard D.Modules please consult our sales department.

WARRANTY

All D.Modules come with a warranty of 12 month.

For additional information contact your local distributor who will also support you after your purchase or contact D.SignT directly.

Distributed and supported locally by

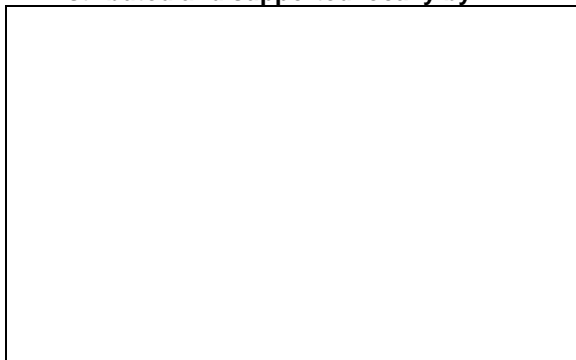

D.SignT

Digital Signalprocessing Technology

Norbert Nölker & Adolf Klemenz GbR

Marktstr. 10

D-47647 Kerken

phone +49 (0) 2833 / 570 977

fax +49 (0) 2833 / 33 28

email info@dsigt.de

www http://www.dsigt.de