

SUMMARY

- High Performance A/D-D/A Converter Board
- 4-Channel A/D with Synchronous Sampling
- 4-Channel D/A with individual or simultaneous update
- 16 Bits Resolution
- 250 kHz Sampling Frequency, (500 kHz two-channel version available)
- +/-5V Analog Supply, 3.3V Digital Supply
- Small Size: only 85 x 59 mm
- industrial grade available

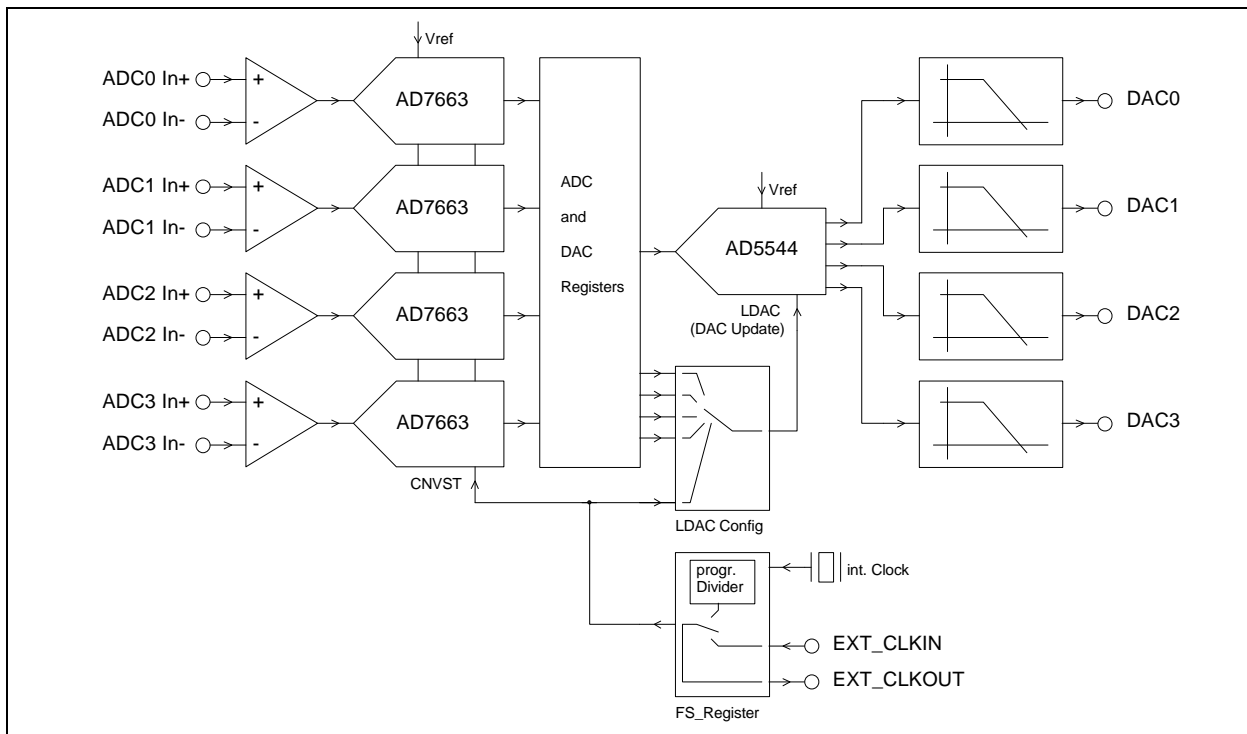

The D.Module.ADDA16 is a 16 bit, 250 KSPS, 4-channel A/D and D/A converter board, suitable for the D.Module family of DSP Computer Modules.

Four A/D channels are converted synchronously using Successive Approximation Converters (SAR). This architecture provides a very short delay from sampling to availability of the digital output word, and is best suited for control loops, where any delay will result in increased dead time, complicating the con-

trol algorithm. Synchronous sampling preserves the phase information of the input channels.

The D/A converters are followed by a second order smoothing filter and provide a single-ended bipolar output. The DACs can be updated synchronously with the ADC, operate in free running mode, or update simultaneously after the last DAC channel has been written.

Analog Inputs

The analog input interface is a differential amplifier which accepts input voltages of +/- 2.5V. Single-ended inputs can be connected by grounding the IN-input.

A/D Converter

The analog-to-digital converters are successive approximation converters with 16 bit resolution and a maximum sampling frequency of 250 kHz. Conversion time is 1.25 μ s, acquisition time is 2.75 μ s, inde-

pendent of the sampling clock. The digital output is serially transmitted to the DSP bus interface, where it is converted into a parallel output word. Data format is 2's complement. A 0V input converts to 0x0000 output word, -2.5V input converts to 0x8000, and the maximum positive input voltage of 2.4999V converts to 0x7FFF. An LSB is 76.3 μ V.

The total ADC latency time is 2.75 μ s + 1.25 μ s + 450 ns (serial-to-parallel conversion) = 4.45 μ s.

Sampling Clock

The A/D converters are triggered either by an internally generated or an externally provided sampling clock. The internal sampling clock is programmable from 15.625 to 250 kHz. The internal sampling clock is available as an output signal to synchronize external hardware or drive additional ADDA16 boards in slave mode.

D/A Converter

The digital-to-analog converters use a serial data interface too. The DSP bus interface logic provides the parallel-to serial conversion. Data is clocked into the DAC with a 40 MHz clock. A transmission takes 20 clock cycles. The DAC settles to 1 LSB accuracy in 2 μ s. Adding the 500 ns for serial transmission, the DAC latency is 2.5 μ s, which must be taken into account as a dead-time in control loops.

The DACs itself use straight binary coding, but the bus interface logic converts 2's complement into straight binary, so the DSP can write it's native 2's complement data to the DAC. A 0x8000 translates to -2.5V on the output, a 0x0000 to 0V output, and 0x7FFFF to +2.4999V.

The four DACs can update their outputs either simultaneously after the last DAC channel has been written, synchronously with the A/D converter sampling clock, or "on-demand", i.e. a DAC output changes immediately after a new value has been written.

Analog Outputs

The D/A converter is followed by a 2nd order Butterworth smoothing filter. This filter attenuates the high frequency switching spikes generated by DAC code transitions and smoothes the output waveform. The analog output is single-ended with +/- 2.5V full-scale output.

DSP Interface

The D.Module.ADDA16 is connected to the DSP via a 16-bit parallel interface in IOSEL memory space. Six registers provide access to the ADCs and DACs, the board configuration, and status. Base address and offset are jumper-selectable and allow to operate multiple ADDA16 in parallel.

Interrupt mapping, sampling clock, and DAC update modes are programmable by the DSP.

ADDRESS DECODING

JPA18	JPA17	JPA16	Base Address w. C6000 DSP Module	Base Address w. other DSP Module
open	open	open	not possible	IOSEL + 0x00.0000
open	open	closed		IOSEL + 0x01.0000
open	closed	open		IOSEL + 0x02.0000
open	closed	closed		IOSEL + 0x03.0000
closed	open	open	IOSEL + 0x00.0000	IOSEL + 0x04.0000
closed	open	closed	IOSEL + 0x04.0000	IOSEL + 0x05.0000
closed	closed	open	IOSEL + 0x08.0000	IOSEL + 0x06.0000
closed	closed	closed	IOSEL + 0x0C.0000	IOSEL + 0x07.0000

JPA5	JPA4	Offset w. C6000 DSP Module	Offset w. other DSP Modules
open	open	0x00	0x00
open	closed	0x40	0x10
closed	open	0x80	0x20
closed	closed	0xC0	0x30

REGISTER MAP

Offset (C6000)	Register	Width	Description
0x00 (0x00)	ADDA0	16 bits	read: ADC channel 0, write: DAC channel 0
0x01 (0x04)	ADDA1	16 bits	read: ADC channel 1, write: DAC channel 1
0x02 (0x08)	ADDA2	16 bits	read: ADC channel 2, write: DAC channel 2
0x03 (0x0C)	ADDA3	16 bits	read: ADC channel 3, write: DAC channel 3
0x04 (0x10)	FS	8 bits	sampling frequency register
0x05 (0x14)	CONFIG	8 bits	configuration register

CONFIG REGISTER

D7	D6	D5	D4	D3	D2	D1	D0
write: EXTCLKOUT read: DACREADY	INT1CFG		INT0CFG		LDACCFG		
EXTCLKOUT: 0 - output off 1 - output on DACREADY: 0 - DAC not ready 1 - DAC ready for new data	00 - INT1 not used 01 - INT1 = ADC ready 10 - INT1 = DAC ready 11 - INT1 = sampfreq	00 - INT0 not used 01 - INT0 = ADC ready 10 - INT0 = DAC ready 11 - INT0 = sampfreq	000 - DACs updated after any write 001 - simultaneous update after write to DAC1 010 - simultaneous update after write to DAC2 011 - simultaneous update after write to DAC3 100 - simultaneous DAC update synchronous with ADC				

SIGNAL DESCRIPTION

DSP BUS INTERFACE

Signal	Pin	Type	Description
A0 .. A5 A16 .. A18	U9 .. U14, V12 .. V14	I	address bus
D0 .. D15	U15.. U30	I/O/Z	data bus (connects to DSP D16..D31)
nRD	U2	I	active low read strobe signal
nWR	U5	I	active low write strobe signal
nIOSEL	U8	I	active low memory select signal
BUSCLK	U6	I	DSP bus clock
nINT0	U3	O/Z	Interrupt Line 0
nINT1	U4	O/Z	Interrupt Line 1

POWER SUPPLY

Signal	Pin	Type	Description
VCC	A1, B32	PWR	digital power supply, 3.3V
GND	A32, B1	PWR	digital ground, 0V
+AVCC	C17	PWR	analog power supply, +5V
AGND	C16	PWR	analog ground, 0V
-AVCC	C15	PWR	analog power supply, -5V

CLOCKS

Signal	Pin	Type	Description
EXT_CLKIN	C22	I	input for external sampling clock
EXT_CLKOUT	C23	O/Z	sampling clock output

ANALOG INPUTS

Signal	Pin	Type	Description
IN0+	G1	I	non-inverting input, ADC channel 0
IN0-	G2	I	inverting input, ADC channel 0
IN1+	I1	I	non-inverting input, ADC channel 1
IN1-	I2	I	inverting input, ADC channel 1
IN2+	K1	I	non-inverting input, ADC channel 2
IN2-	K2	I	inverting input, ADC channel 2
IN3+	M1	I	non-inverting input, ADC channel 3
IN3-	M2	I	inverting input, ADC channel 4
AGND	H1, H2, J1, J2, L1,L2	PWR	analog ground, 0V

ANALOG OUTPUTS

Signal	Pin	Type	Description
OUT0	G31	O	output DAC channel 0
OUT1	I31	O	output DAC channel 0
OUT2	K31	O	output DAC channel 0
OUT3	M31	O	output DAC channel 0
AGND	G32, H31, H32, I32, J31, J32, K32, L31,L32, M32	PWR	analog ground, 0V

PINOUT

Pin	A	B	C	T	U	V
1	VCC (3.3V)	GND				
2					nRD	
3					nINT0	
4					nINT1	
5					nWR	
6					BUSCLK	
7					nRESET	
8					nIOSEL	
9					A0	
10					A1	
11					A2	
12					A3	A16
13					A4	A17
14					A5	A18
15			-AVCC (-5V)		D0	
16			AGND		D1	
17			+AVCC (+5V)		D2	
18					D3	
19					D4	
20					D5	
21					D6	
22			EXT_CLKIN		D7	
23			EXT_CLKOUT		D8	
24					D9	
25					D10	
26					D11	
27					D12	
28					D13	
29					D14	
30					D15	
31						
32	GND	VCC (3.3V)		GND		GND

Pin	1	2	31	32
F	+AVCC * ¹	-AVCC * ¹	+AVCC * ¹	-AVCC * ¹
G	ADC channel 0 IN+	ADC channel 0 IN-	DAC channel 0 OUT	AGND
H	AGND	AGND	AGND	AGND
I	ADC channel 1 IN+	ADC channel 1 IN-	DAC channel 1 OUT	AGND
J	AGND	AGND	AGND	AGND
K	ADC channel 2 IN+	ADC channel 2 IN-	DAC channel 2 OUT	AGND
L	AGND	AGND	AGND	AGND
M	ADC channel 3 IN+	ADC channel 3 IN-	DAC channel 3 OUT	AGND
N	VCC * ¹	GND * ¹	VCC * ¹	GND * ¹
O	rsvd	rsvd	rsvd	rsvd
P	rsvd	rsvd	rsvd	rsvd

*¹ use as outputs to supply external analog and digital I/O circuitry only !

MECHANICAL DIMENSIONS

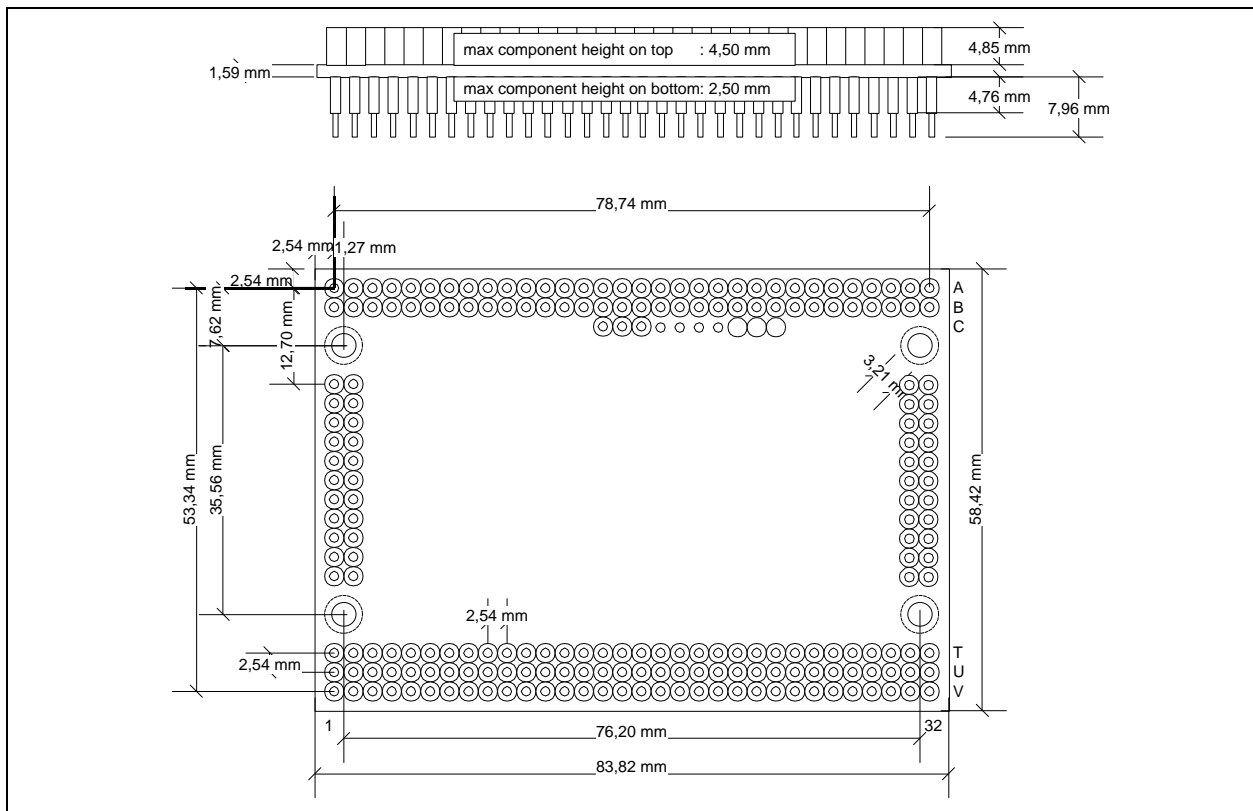

Size: max. 85 x 59 x 15 mm

ELECTRICAL CHARACTERISTICS

OPERATING CONDITIONS, DC PARAMETERS

Supply Voltage	digital: 3.3V +/- 5% analog: +/-5V +/-10%
Power Consumption	digital: 400 mA typ. analog: 150 mA typ.
Operating Temperature	0..+70°C optional -40..+85°C
High Level Input Voltage	min. 2V, max. 5.5V
Low Level Input Voltage	min. -0.2V, max. 0.8V

ANALOG INPUTS

Channels	4, differential (single-ended: connect IN- to AGND)
Input Voltage Range	+/- 2.5V
Input Impedance	200 kOhms differential, 100 kOhms single.-ended
Input Bandwidth	800 kHz
Input Offset Voltage	TBD

ANALOG OUTPUTS

Channels	4, single-ended
Output Voltage Range	+/-2.5V, outputs default to 0V after power-on
Output Offset Voltage	TBD
Smoothing Filter	Butterworth, 2 nd order, fc=200kHz
Load	> 2 K Ohms

ANALOG-TO-DIGITAL CONVERTER

Type	successive approximation
Resolution	16 bit
Acquisition Time	2.75 µsecs
Conversion Time	1.25 µsecs
Sampling Frequency	internal 15.625 .. 250 kHz, optional 500 kHz external 0 .. 250 kHz, optional 500 kHz
Signal-to-Noise Ratio	TBD
SINAD	TBD

DIGITAL-TO-ANALOG CONVERTER

Type	R2R ladder
Resolution	16 bit
Monotonicity	15 bit
Settling Time	< 2 µsecs full-scale step to 1 LSB
Update Frequency	max 250 kHz
Signal-to-Noise Ratio	TBD
SINAD	TBD

DSP BUS INTERFACE

Read Timing	t_{ACC} (IOSEL, ADDR, RD) valid to data valid: < 30 nsecs
Write Timing	t_{SETUP} data valid before (IOSEL, ADDR, WR): > 20 nsecs t_{HOLD} data valid after (IOSEL, ADDR, WR): > 0 nsecs

ORDERING INFORMATION

D.Module.ADDA16-4-4	standard module
D.Module.ADDA16-500-2-2	two ADC channels, 500 kHz sampling two DAC channels
options: - I	industrial temperature range

ADDITIONAL OPTIONS ON VOLUME PURCHASE

For volume purchase D.SignT offers customer-specific modifications of the hardware either to reduce costs through reduced functionality or to increase functionality to meet the customers application requirements. Extensive experience in custom designs and the powerful engineering tools of our development department bring your application and our DSP know how together for your solution. Please contact D.SignT directly.

TECHNICAL SUPPORT

Our products include free of charge technical support. You can reach the technical support by e-mail (support@dsigt.de) phone or fax.

PRICING

Please ask for our current price list and volume discounts.

AVAILABILITY

Our standard D.Modules are available typically ex-stock. For special modifications or non-standard D.Modules please consult our sales department.

WARRANTY

All D.Modules come with a warranty of 12 month.

For additional information contact your local distributor who will also support you after your purchase or contact D.SignT directly.

Distributed and supported locally by

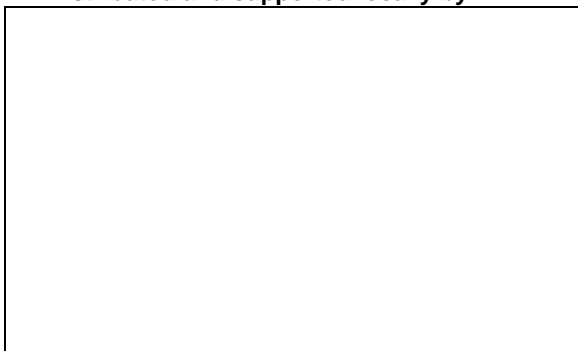

D.SignT

Digital Signalprocessing Technology

Norbert Nölker & Adolf Klemenz GbR

Gelderner Strasse 36

D-47647 Kerken

phone +49 (0) 2833 / 570 977

fax +49 (0) 2833 / 33 28

email info@dsigt.de

www http://www.dsigt.de