

SUMMARY

- 4 / 8-Channel Audio Codec Board
- 8 to 48 kHz Sampling Frequency
- 16 Bit Resolution, 90dB Dynamic Range
- 64x Oversampling $\Delta\Sigma$ ADCs and DACs
- 1.8Vpp Full-Scale Input and Output Range
- Low Power: 3.3V / 85mA typ.
- Serial Interface to DSP
- Small Size: only 85 x 59 mm
- -25 to +85°C Temperature Range

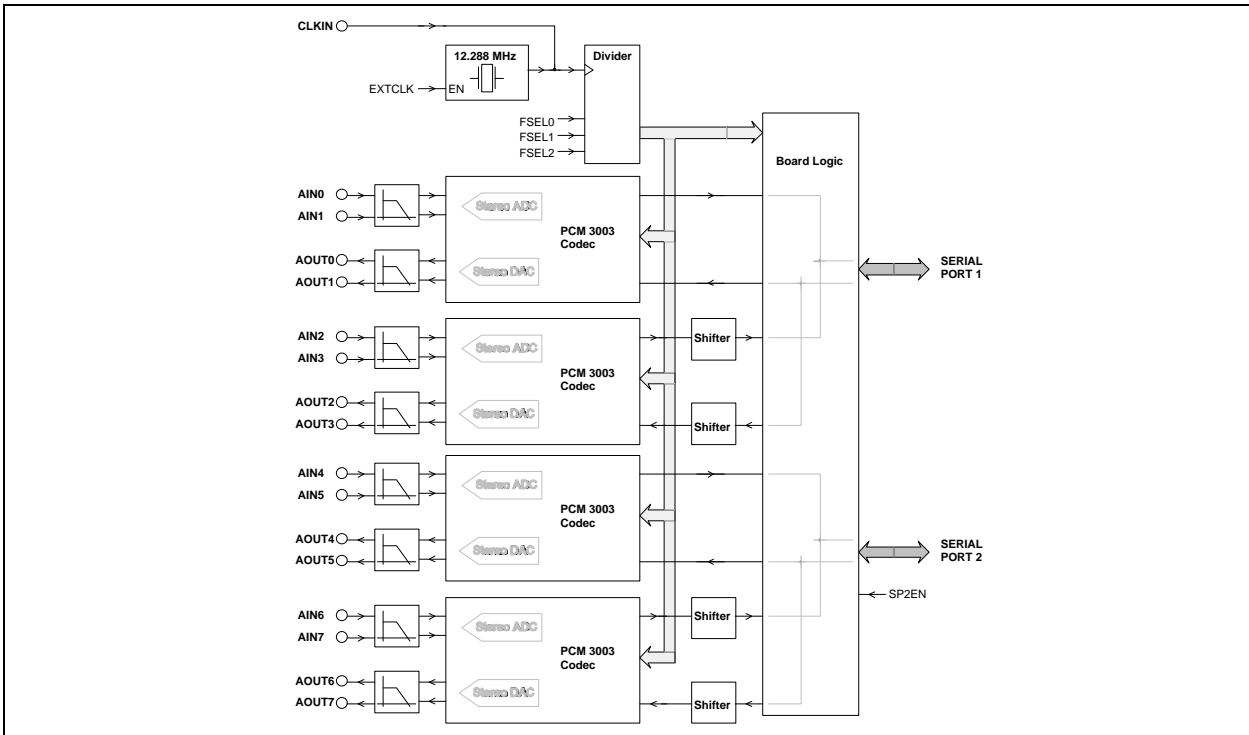

D.Module.PCM3003 Block Diagram

The D.Module.PCM3003 is a high performance Audio Codec board, particularly suited for multi-channel audio and voice processing, beam-forming

microphone arrays, speech recognition, and vibration analysis. It is available in four-channel and eight-channel configuration.

Analog Inputs

The analog inputs are single-ended and AC-coupled with a cut-off frequency of 3 Hz. A first order RC lowpass filters high frequency noise and provides additional alias frequency rejection. Input impedance in 30 kOhms. The full-scale input voltage is 1.8V_{pp} (600 mV_{rms}). The inputs are fail-safe up to +/- 5V, hence no special precautions are required if any driving amplifier operates from a +/- 5V (or lower) power supply.

Analog Outputs

The DAC outputs are AC-coupled with 2 Hz cut-off frequency with nominal load. They are followed by a first order RC filter to provide additional alias image rejection. Output impedance is 350 ohms. The load

impedances must be 10 kOhms or higher. Full-scale output voltage is 1.8V_{pp} (600mV_{rms}).

Sampling Clock

The sampling clock is derived from a 12.288 MHz oscillator followed by a jumper-configurable divider. The nominal sampling frequencies are 8, 12, 16, 24, 32, and 48 kHz.. All A/D and D/A converters operate synchronous to the sampling clock. Other sampling frequencies can be obtained using an external clock at 256 * fs or higher. This configuration also allows to synchronize the module to an external master clock.

Power Supply

The D.Module.PCM3003 requires a single 3.3V power supply. A filter is included in the power supply

line, which allows to use the 3.3V DSP power supply with only minimum impact on noise performance.

DSP Interface

The D.Module.PCM3003 is connected to the DSP board via one (4-channel configuration) or two (8-channel configuration) serial interfaces. Clocks and frame synchronization signals are generated by the PCM3003 module.

Isolation

If galvanic isolation of the analog inputs should be required, this can easily be achieved using optocouplers in the serial DSP interface and an isolated DC/DC converter for the power supply. The serial interface is not capable of driving the required diode forward current of typical optocouplers. You must add buffers (e.g. 74HC or 74LVC types) to provide the required current, or use optocouplers with build-in buffers.

MAXIMUM RATINGS

Power Supply	+3.6V
Analog Input Voltage	+/-5V
Digital Input Voltage	-0.3 to 3.3V (serial port, external clock input)
Operating Temperature	-25 to +85°C

ELECTRICAL CHARACTERISTICS

Inputs	4 or 8, single ended
Input Impedance	30 K Ohms
Frequency Range	20 Hz .. 0.45 * sampling frequency (-0.3 dB)
Input Voltage	1.8V _{pp} full scale
Outputs	4 or 8, single ended
Output Impedance	350 Ohms
Frequency Range	20 Hz .. 0.45 * sampling frequency (-0.3dB)
Output Voltage	1.8V _{pp} full scale
Output Load	> 10 K Ohms
Resolution	16 Bits
Dynamic Range	A/D converter: 90dB typ (A-weighted) D/A converter: 90dB typ (A-weighted)
THD&N	A/D converter: 86dB typ with -0.5dBFS input signal D/A converter: 86dB typ at full scale output
Sampling Frequency	selectable: internally generated 8, 12, 16, 24, 32, or 48 kHz or external frequency at 256, 384, 512, 768, 1024, or 1536 * fs (valid fs range is 8 to 48 kHz)
Power Supply	3.3V +/- 10%, 85 mA typ. (4-channel version: 55 mA)

PINOUT

Pin	A	B	C	T	U	V
1	VCC (+3.3V)	GND (0V)				
2						
3						
4						
5						
6						
7					nRESET	
8						
9						
10						
11						
12						
13						
14						
15						
16			AGND			
17						
18						
19						
20						
21						
22			EXT CLKIN			
23			GND			
24						
25						
26	DAT_RX0	DAT_RX1				
27	CLK_RX0	CLK_RX1				
28	FS_RX0	FS_RX1				
29	DAT_TX0	DAT_TX1				
30	CLK_TX0	CLK_TX1				
31	FS_TX0	FS_TX1				
32	GND (0V)	VCC (+3.3V)				

Pin	1	2	31	32
F	AGND	AGND	AGND	AGND
G	ADC channel 0 IN	ADC channel 4 IN	DAC channel 0 OUT	DAC channel 4 OUT
H	AGND	AGND	AGND	AGND
I	ADC channel 1 IN	ADC channel 5 IN	DAC channel 1 OUT	DAC channel 5 OUT
J	AGND	AGND	AGND	AGND
K	ADC channel 2 IN	ADC channel 6 IN	DAC channel 2 OUT	DAC channel 6 OUT
L	AGND	AGND	AGND	AGND
M	ADC channel 3 IN	ADC channel 7 IN	DAC channel 3 OUT	DAC channel 7 OUT
N	AGND	AGND	AGND	AGND
O	rsvd	rsvd	rsvd	rsvd
P	rsvd	rsvd	rsvd	rsvd

MECHANICS

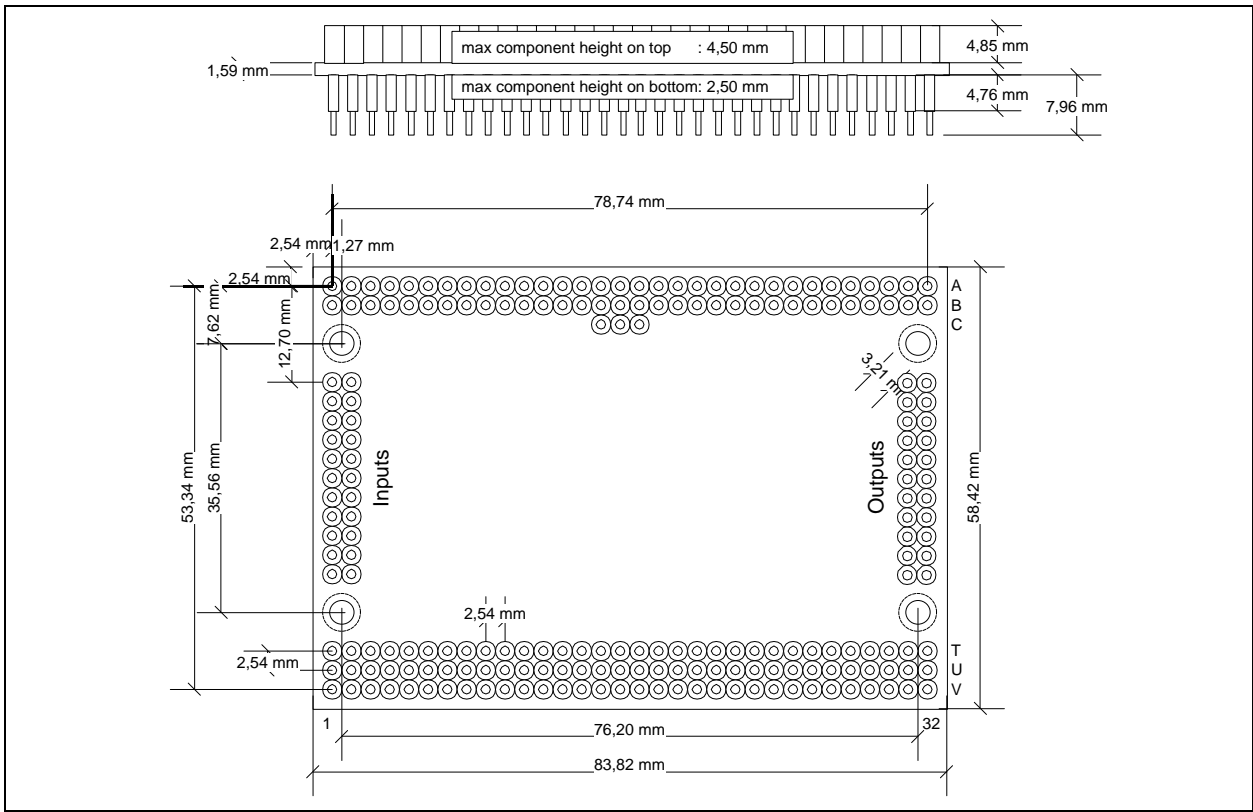

ORDERING INFORMATION

D.Module.PCM3003-4	4-channel board (OEM version, minimum order quantity = 25)
D.Module.PCM3003-8	8-channel board (standard)
Options:	-
DS.PCM3003	Development Support Base Package: User's Guide, Initialization Routines, Sample Programs

ADDITIONAL OPTIONS ON VOLUME PURCHASE

For volume purchase D.SignT offers customer-specific modifications of the hardware either to reduce costs through reduced functionality or to increase functionality to meet the customers application requirements. Extensive experience in custom designs and the powerful engineering tools of our development department bring your application and our DSP know how together for your solution. Please contact D.SignT directly.

TECHNICAL SUPPORT

Our products include free of charge technical support. You can reach the technical support by e-mail (support@dsigt.de) phone or fax.

PRICING

Please ask for our current price list and volume discounts.

AVAILABILITY

Our standard D.Modules are available typically ex-stock. For special modifications or non-standard D.Modules please consult our sales department.

WARRANTY

All D.Modules come with a warranty of 12 month.

For additional information contact your local distributor who will also support you after your purchase or contact D.SignT directly.

Distributed and supported locally by

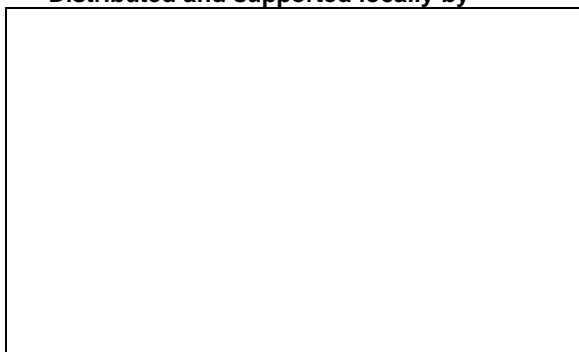

D.SignT

Digital Signalprocessing Technology

D.SignT GmbH & Co. KG

Marktstr. 10

D-47647 Kerken

phone +49 (0) 2833 / 570 977

fax +49 (0) 2833 / 33 28

email info@dsigt.de

www http://www.dsigt.de